



Materiali Fotocromici: come dare un po' di colore ad uno spettrografo

Andrea Bianco
Astro-SIESTA, 5 luglio 2007

gOlem

Osservatorio Astronomico di Brera – Merate



Dip. G. Natta
Politecnico di Milano

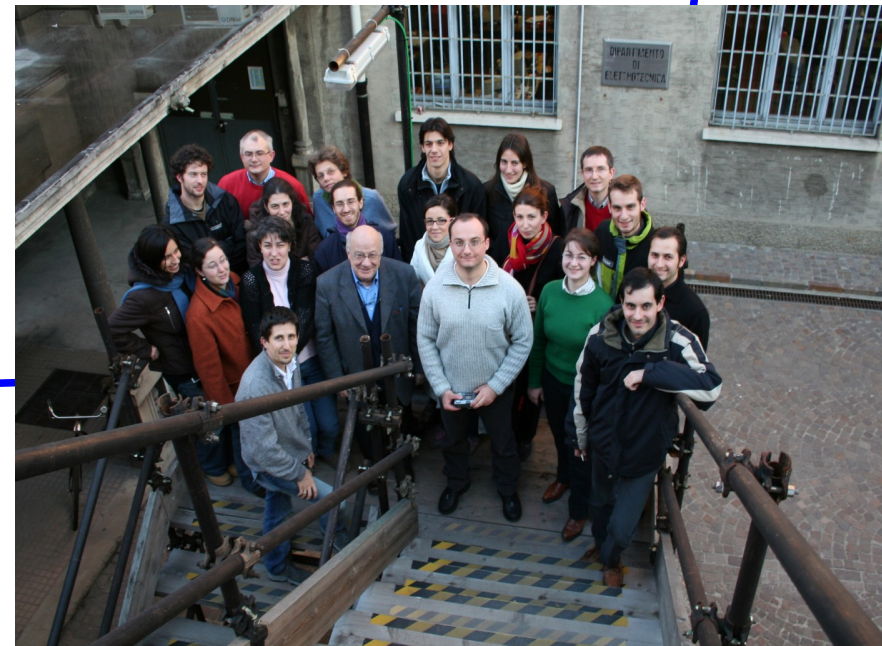
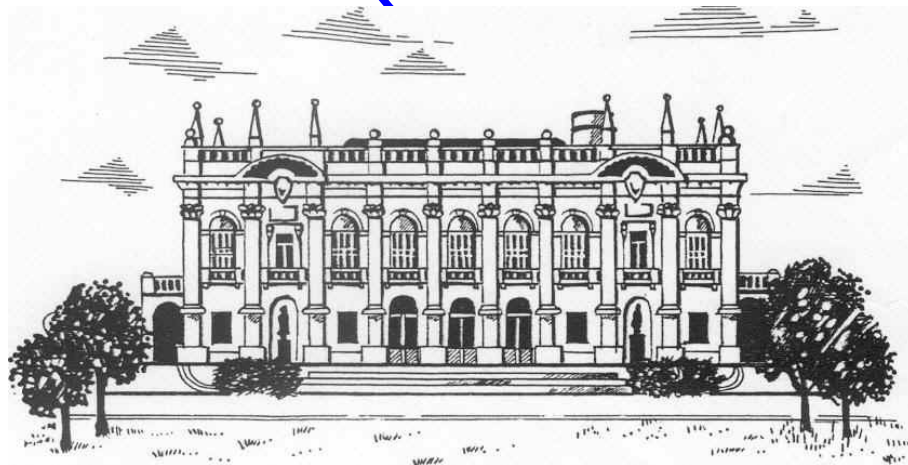

Materiali Funzionali

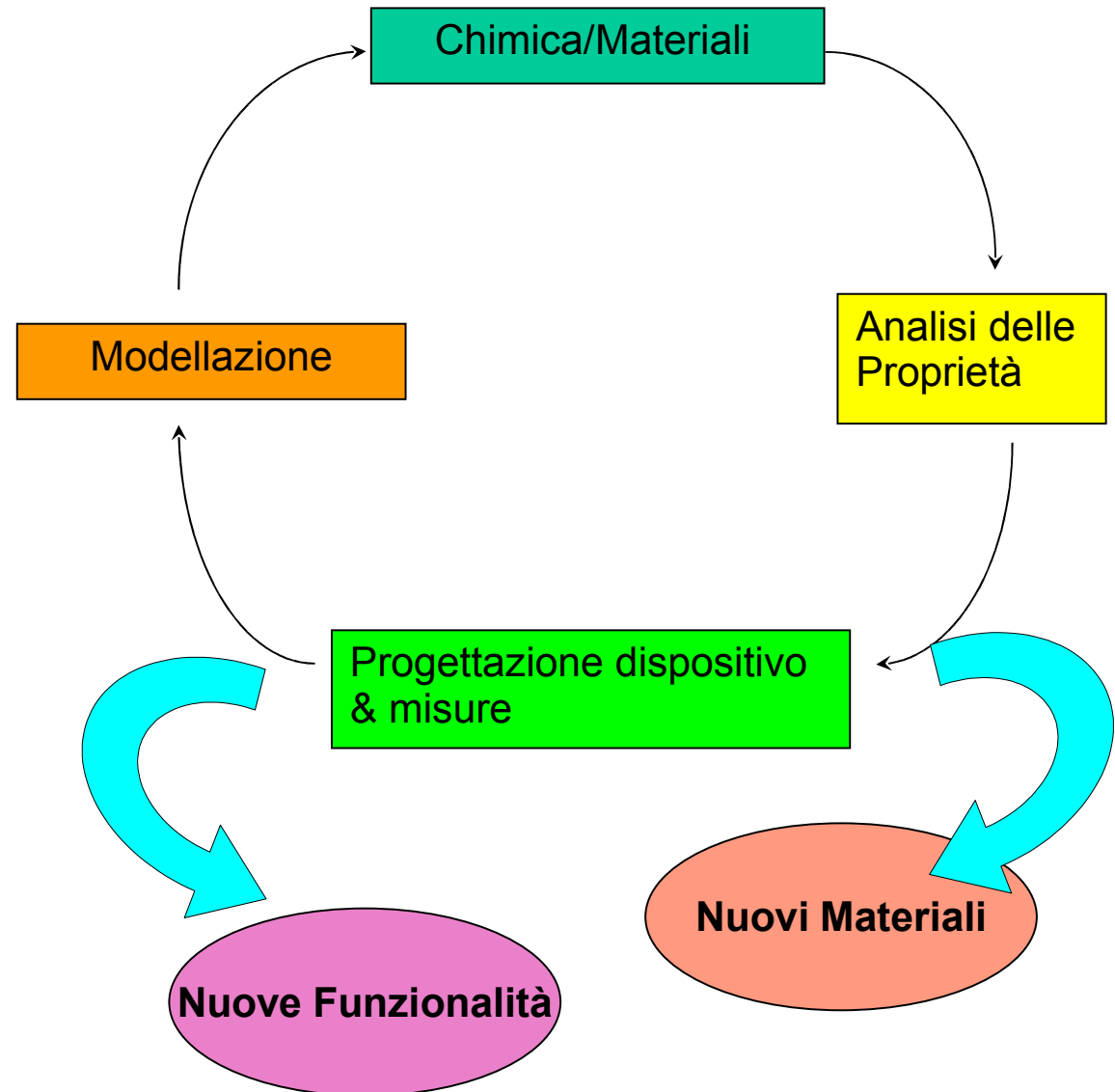
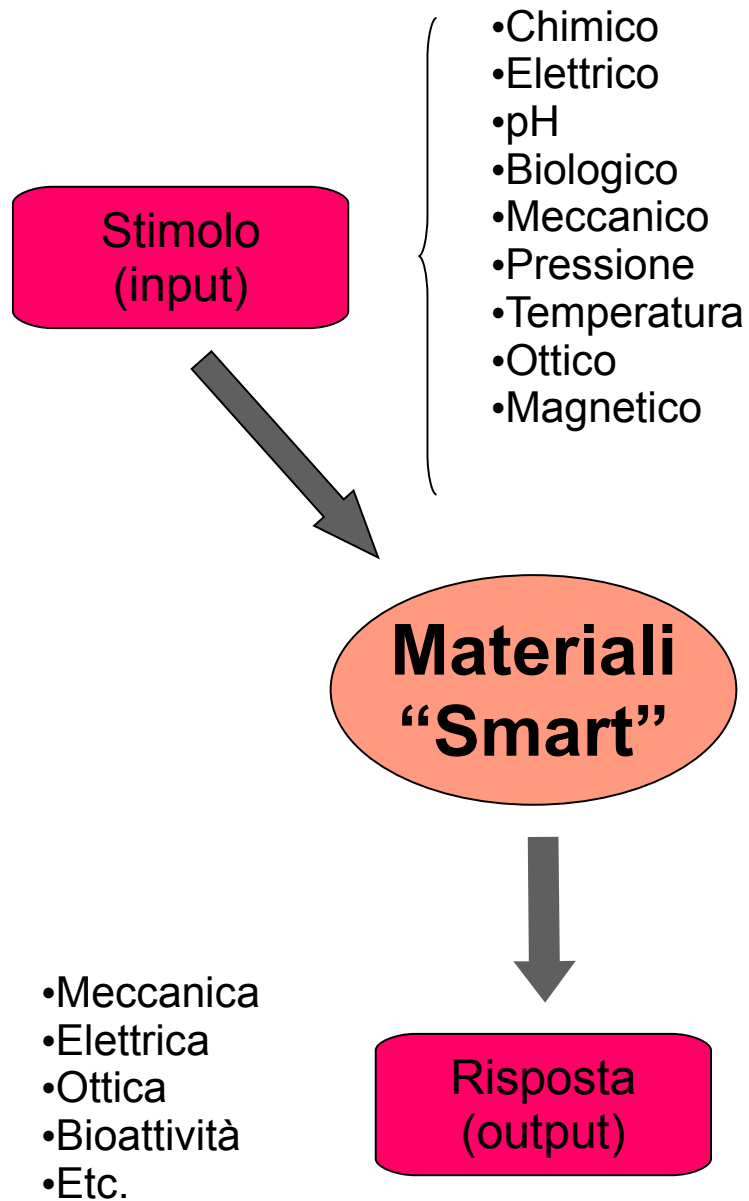

Photochromic materials

Reversible chemical transformation between two stable forms

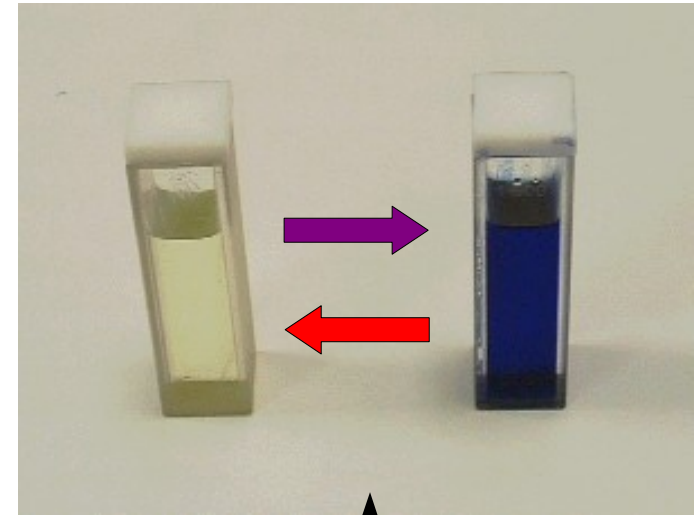
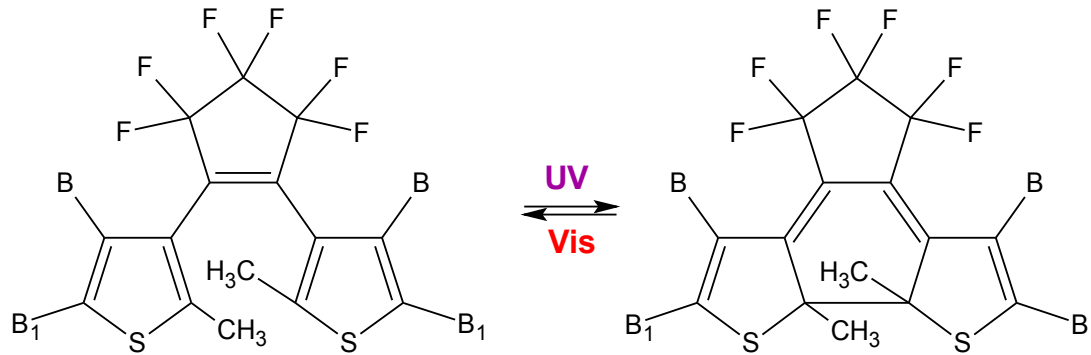

The chemical substituents B and B₁ allow to tailor the chemical/physical properties of the photochromic materials.

Properties

- Absorption wavelength
- Quantum Yield
- Thermal stability
- Fatigue resistance

There is a strong reversible change in color

Many other properties are different between the two forms:

- Refractive index
- Infrared spectrum
- REDOX potential

.....

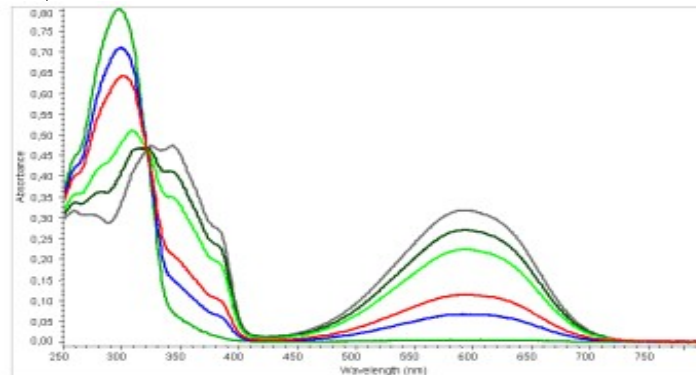

What can we do with photochromic materials?

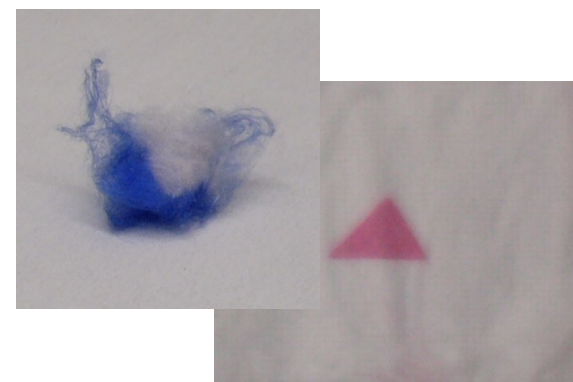

vis

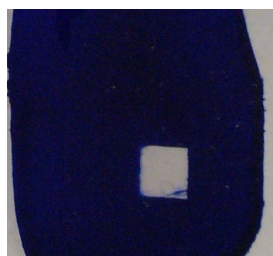

Mid-IR

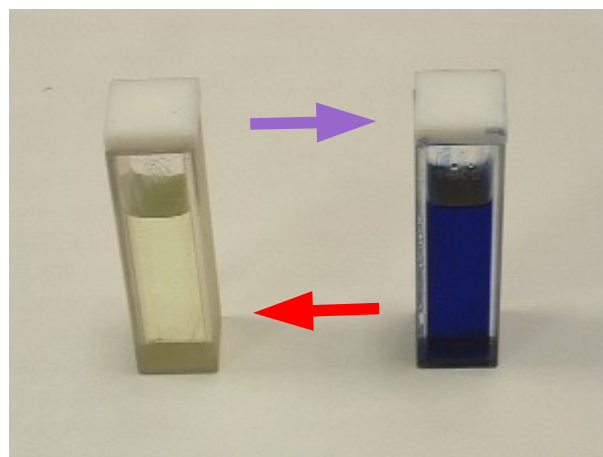
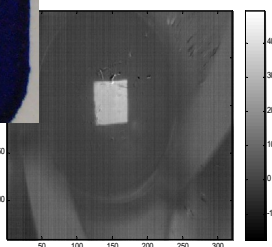

2 reazioni fotoindotte

Thermal decoloration

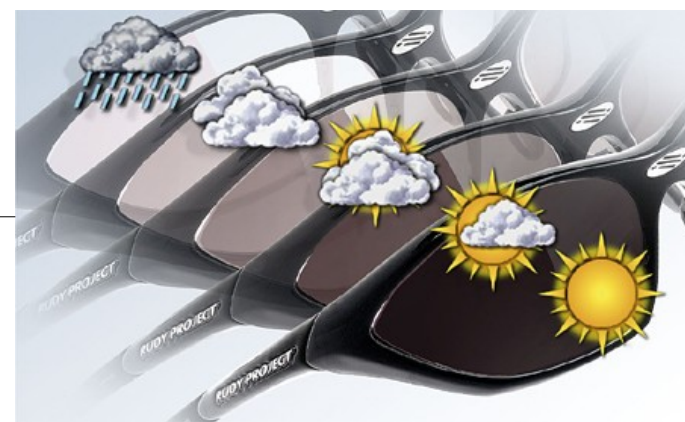
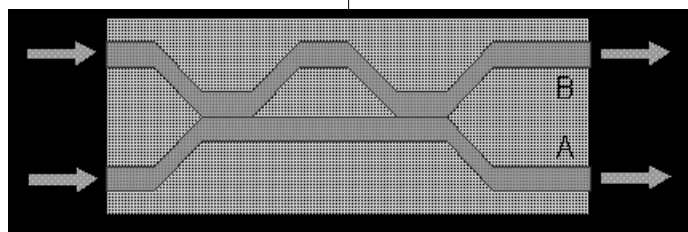

Sviluppo rapido del colore

Controllo della reazione di decolorazione

Ampio intervallo di colori

Stabilita' delle due forme

Vita utile lunga

Photochromic Film...

VIS

NIR

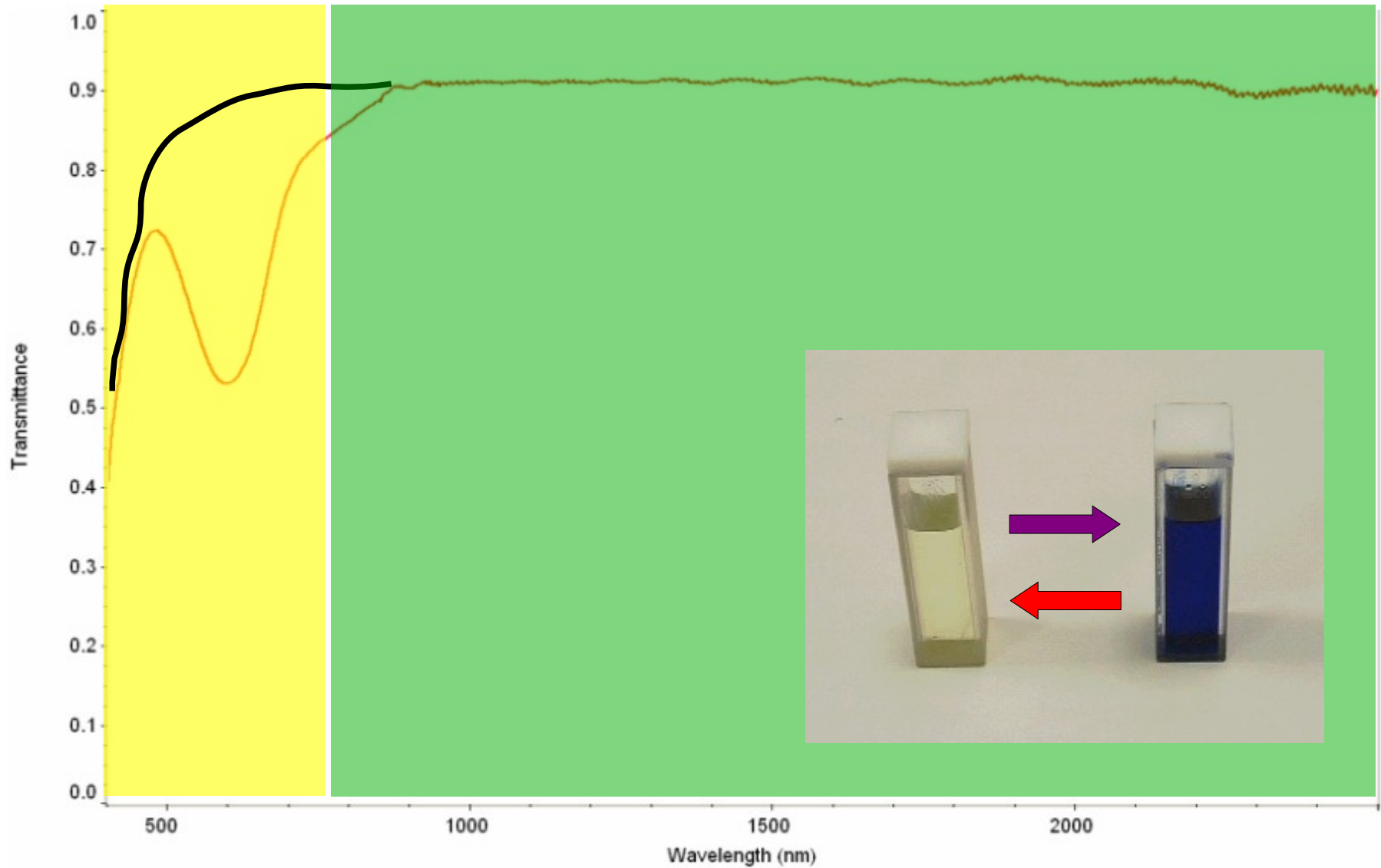

Strong Absorption:
Change in transparency

No Absorption:
Change in the refractive index (real part)

Reversible Modulation of Optical Properties

The ability of changing the optical properties reversibly is intriguing, especially if the switching tools are “clean” like photons!

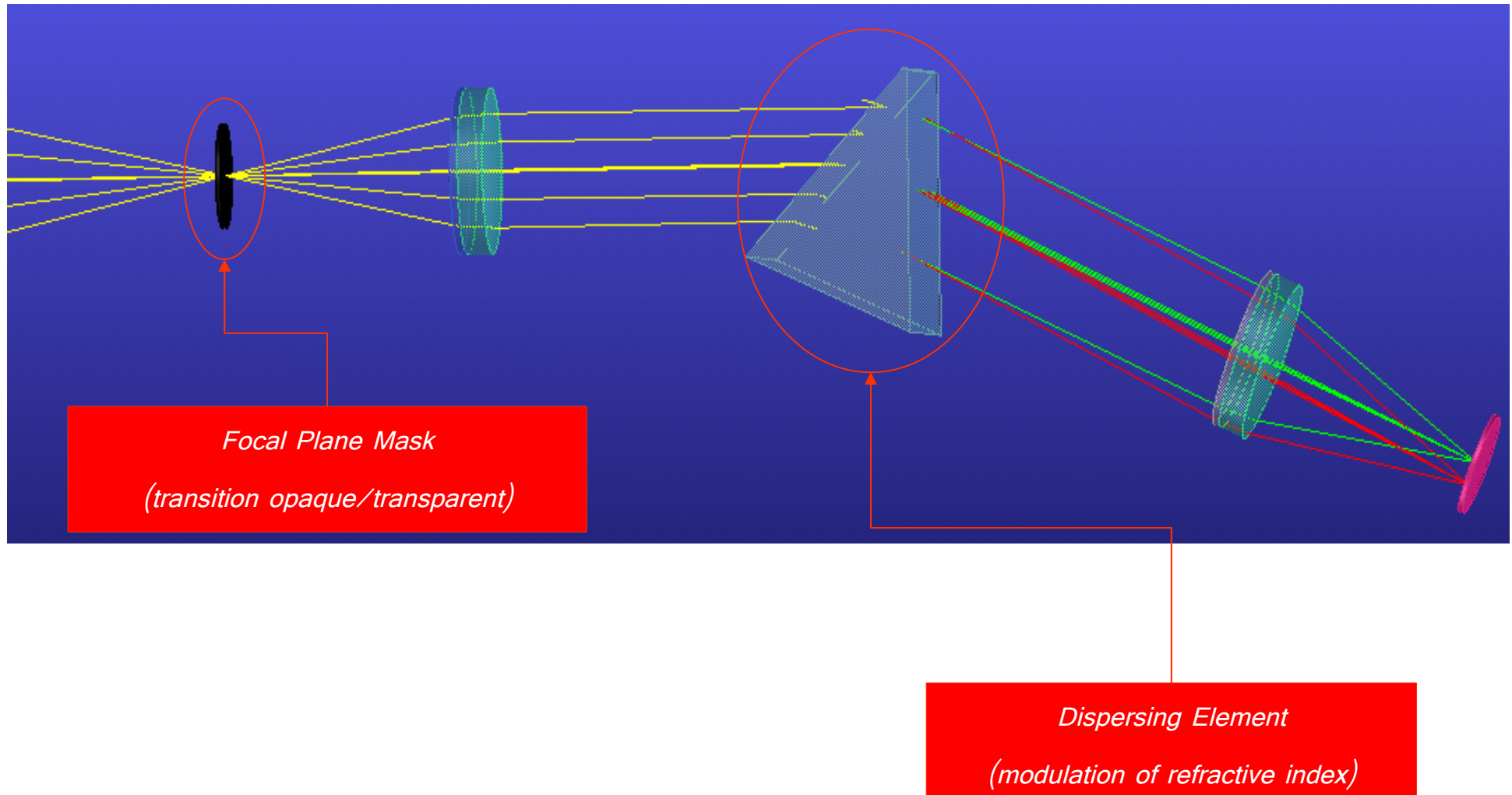

MOS (Multi Object Spectroscopy) Focal Plane Masks

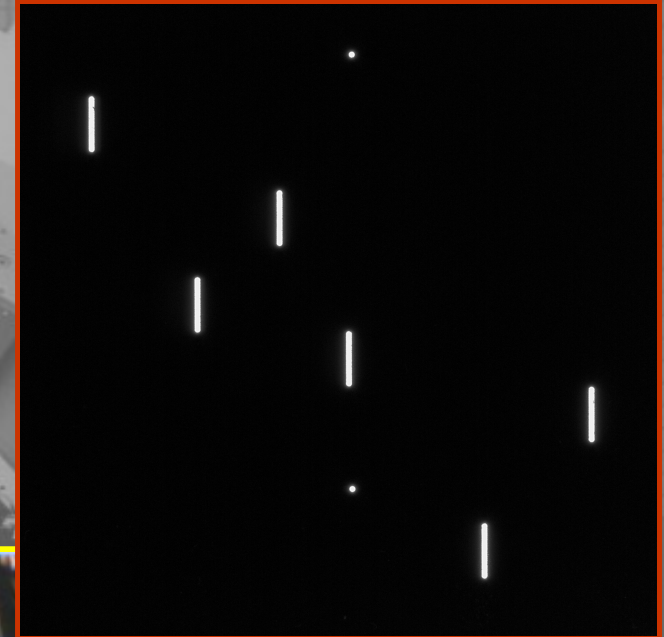

Photochromic focal plane mask:

- Rewritable
- contrast in a specific spectral region
- easy to use

Traditional focal plane mask:

- well established technology
- highest contrast
- disposable

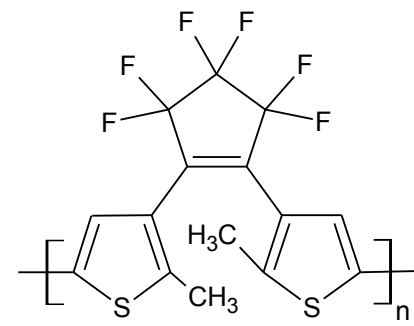
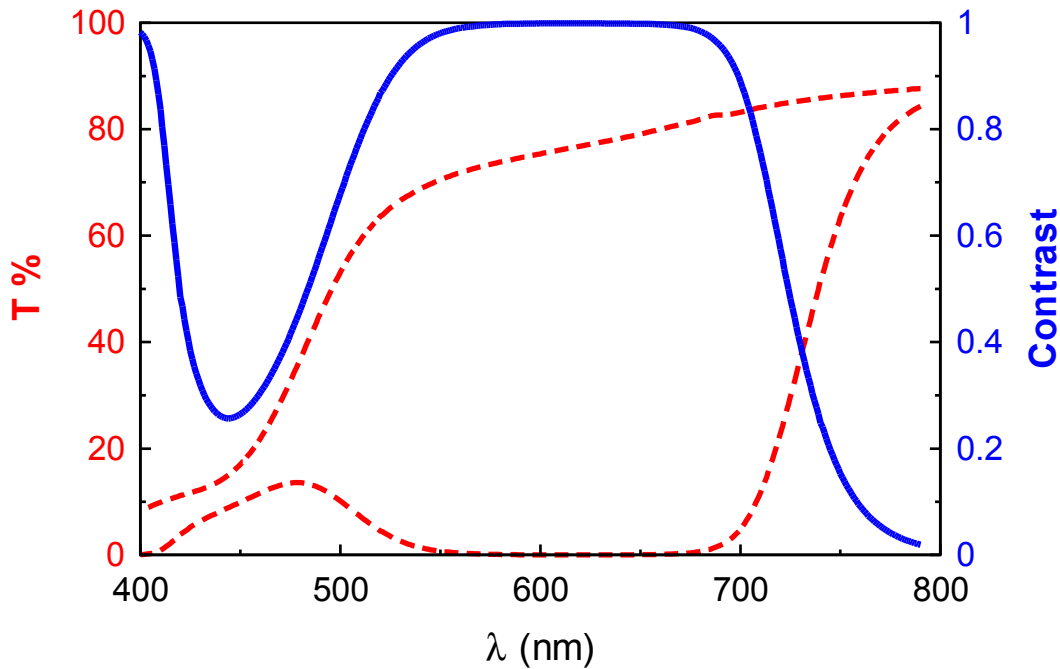

- A 70 μm thick film of P1 (6%) in PMMA (we need a polymer matrix!)
- The contrast is large in a wide spectral range of astronomical interests ($\text{H}\alpha$, Na,...).

• Filters are needed to make opaque the mask over the entire visible spectral range.

• The transmission curve of filters must fit the curve of photochromic material.

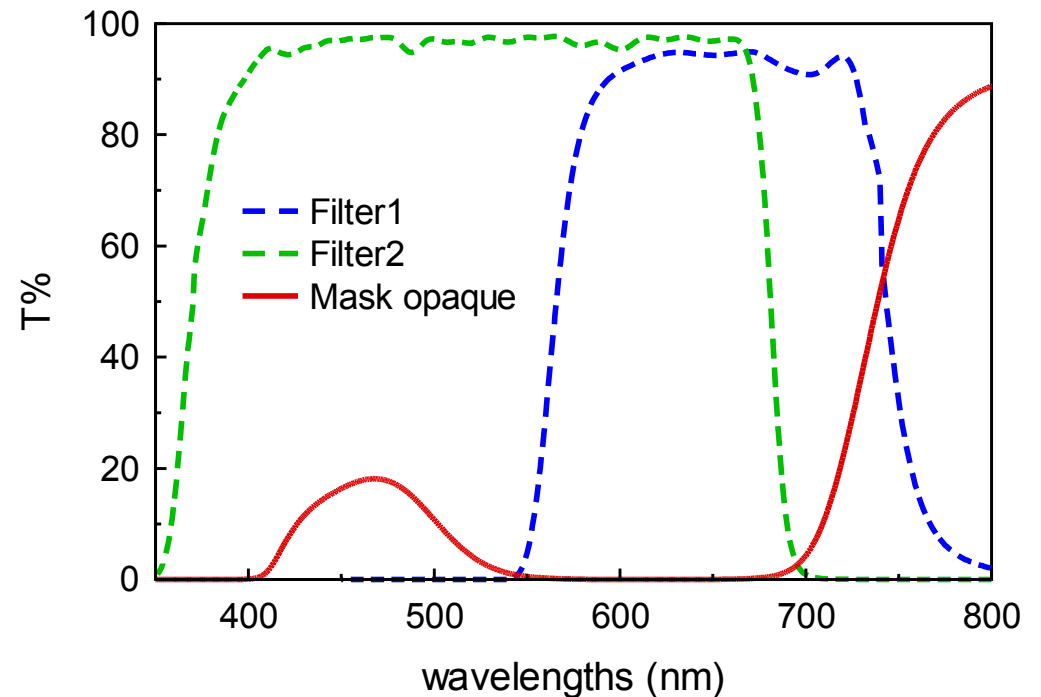

ARATRO

Writing software
and hardware

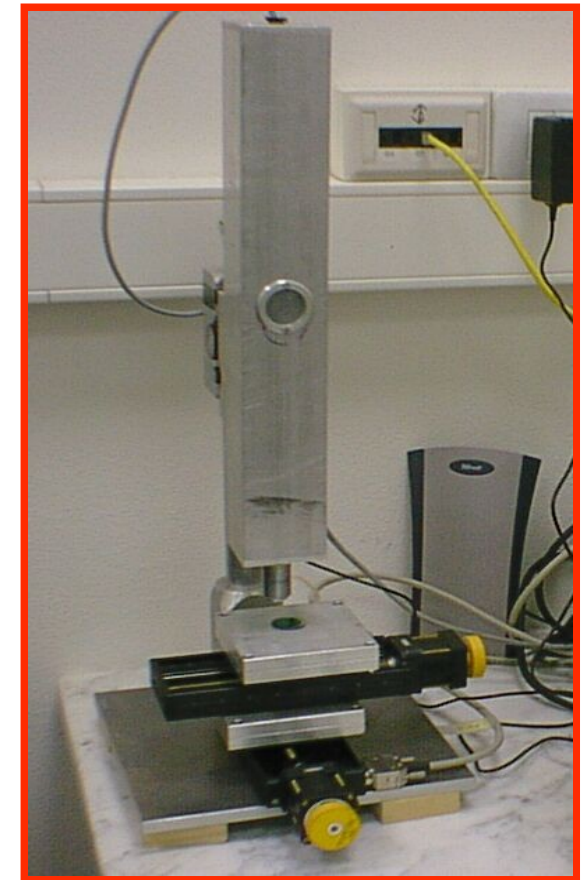
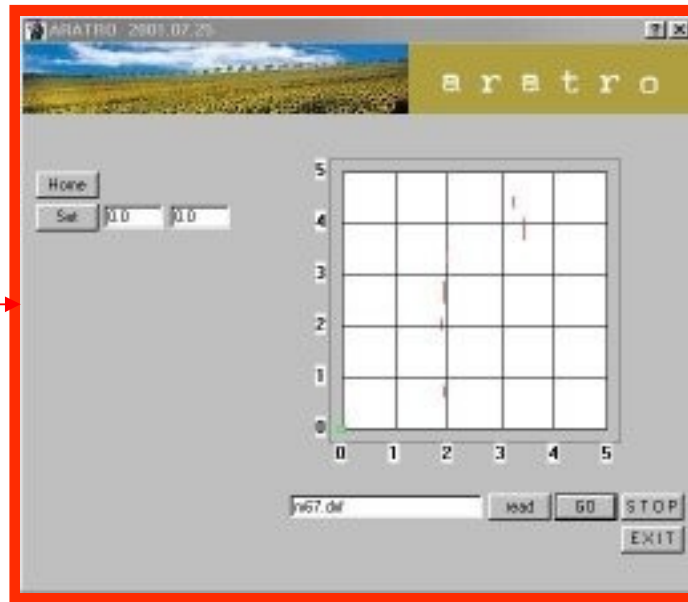

from the telescope...

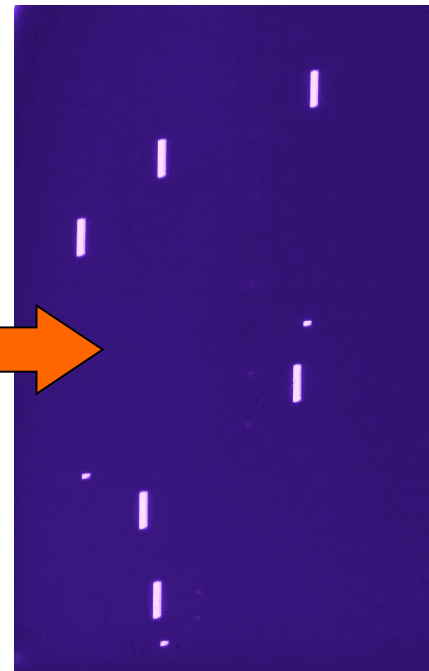
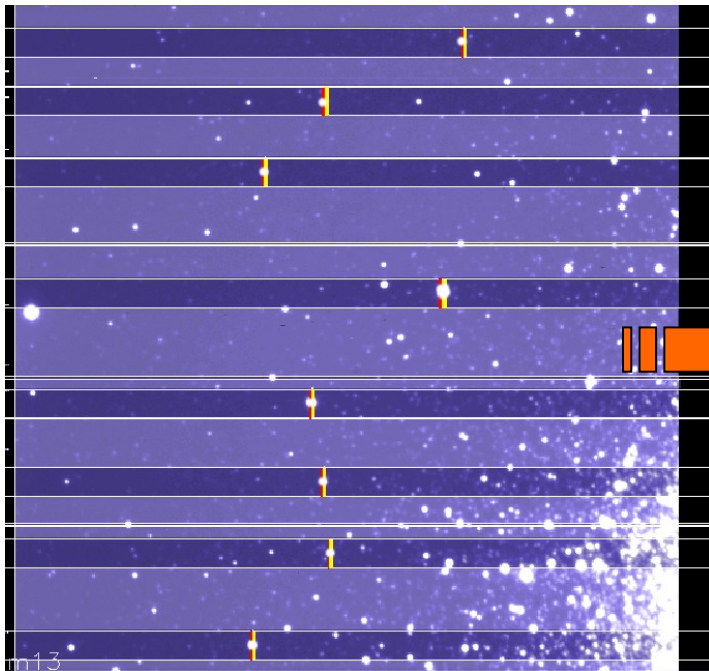

... to the mask

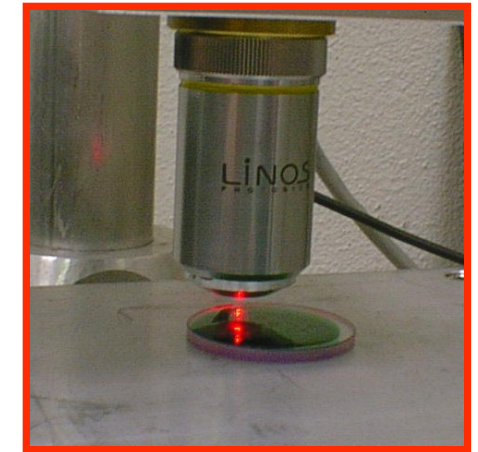

Positioning error: rms (on the whole mask area) = $16 \mu\text{m}$ (0.2 arcsec in the sky)

Photochromic FPM vs Metallic FPM @ Asiago Telescope

CCD image of a slit

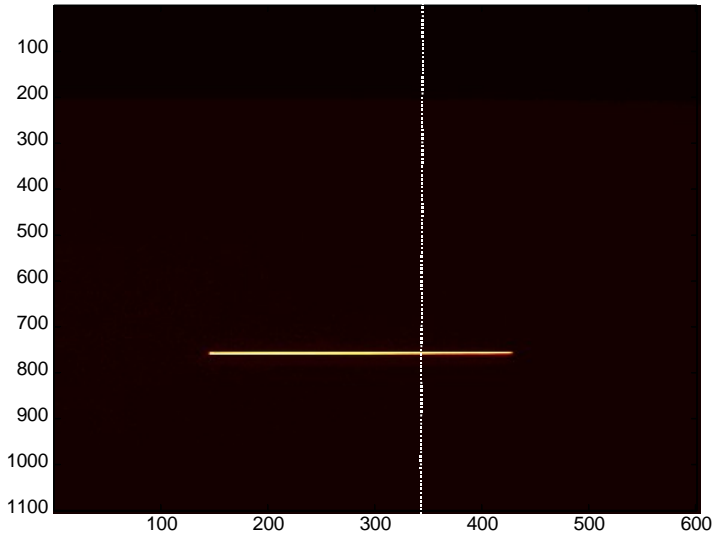

CCD image of a slit with a dispersing element

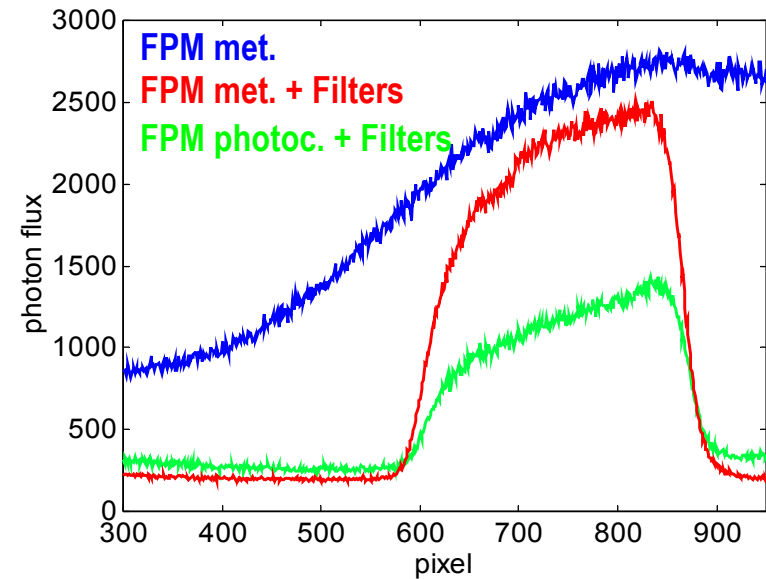
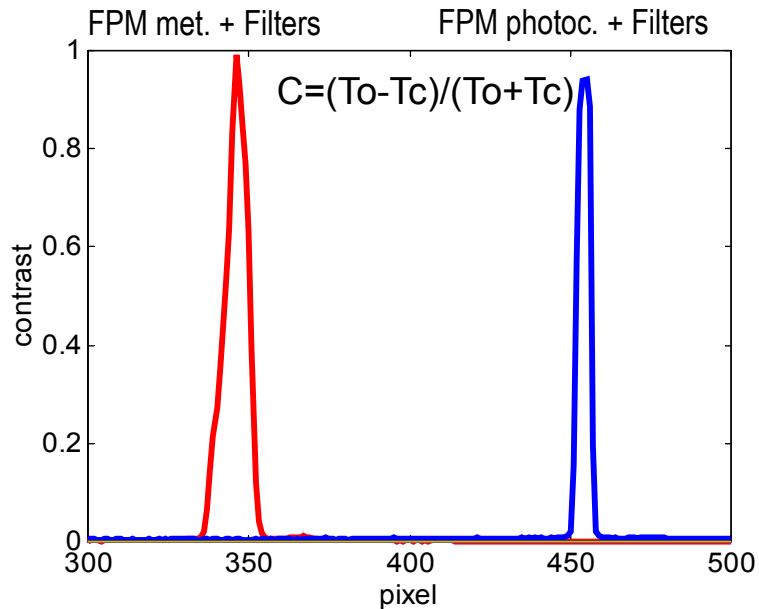
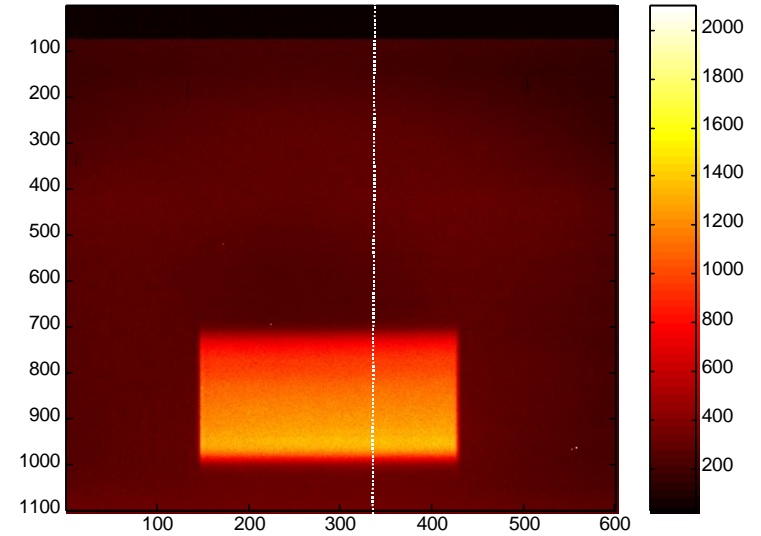

Photochromic MOS mask @ Asiago Telescope*

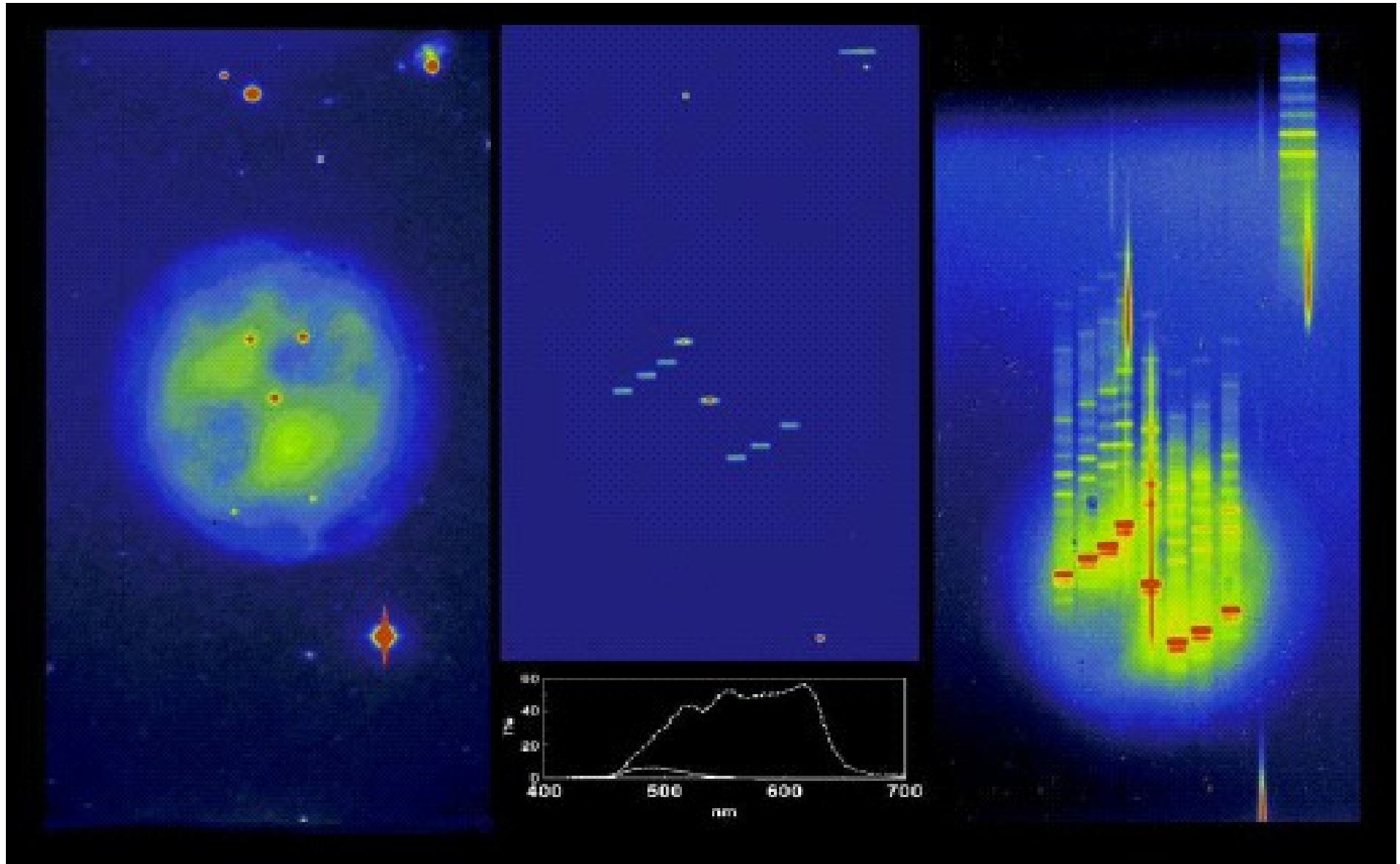

Now we can erase it and write another slit pattern...

Photochromic MOS mask @ Asiago Telescope*

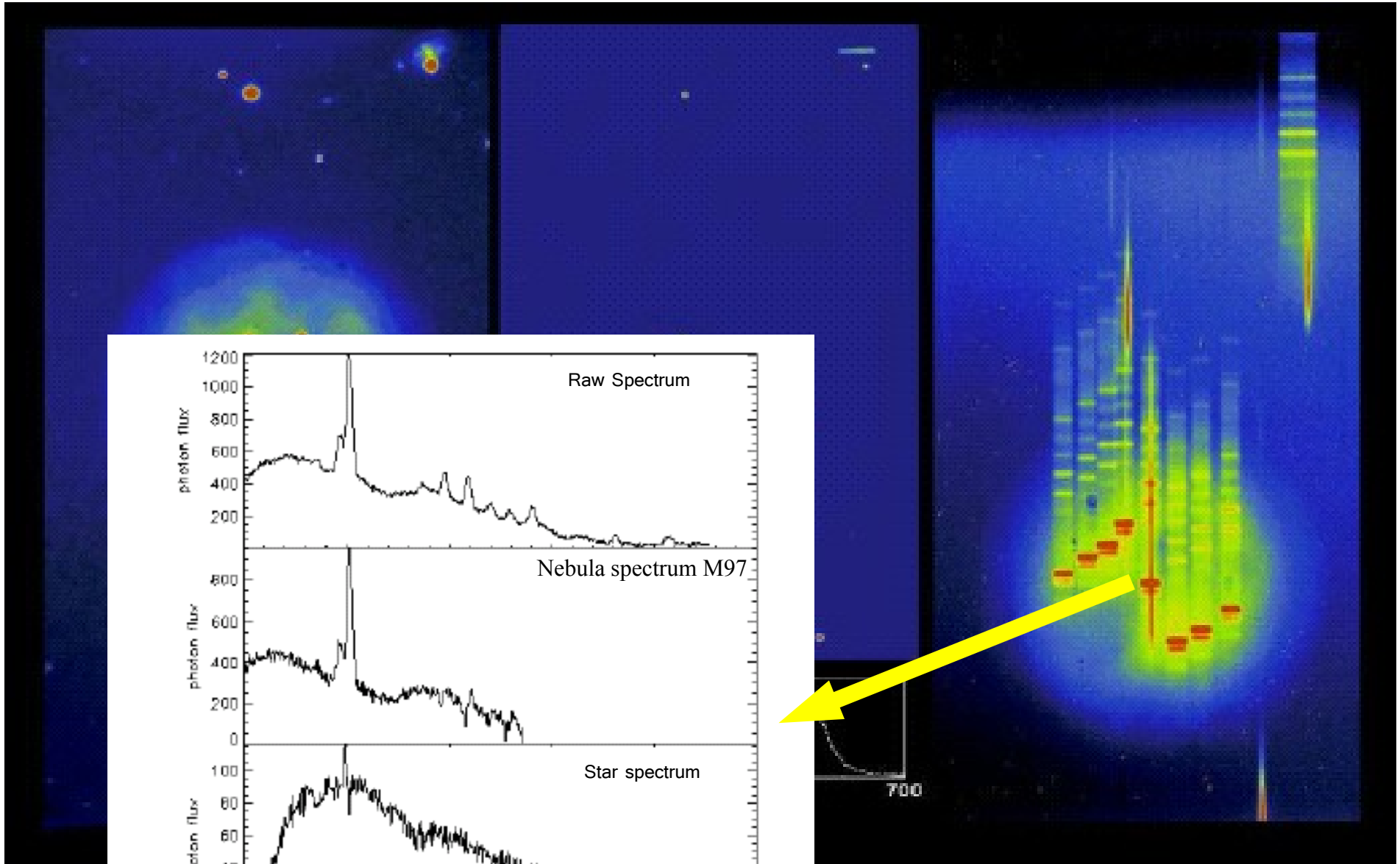

Now we can erase it and write another slit pattern...

*Bianco A., Bertarelli C., Gallazzi M.C, Zerbi G., Giro E., Molinari E., *Astron. Nachr.*, **326** (5) pp. 370–374, 2005

Reversible Modulation of Refractive Index

The ability of changing the optical properties reversibly is intriguing, especially if the switching tools are “clean” like photons!

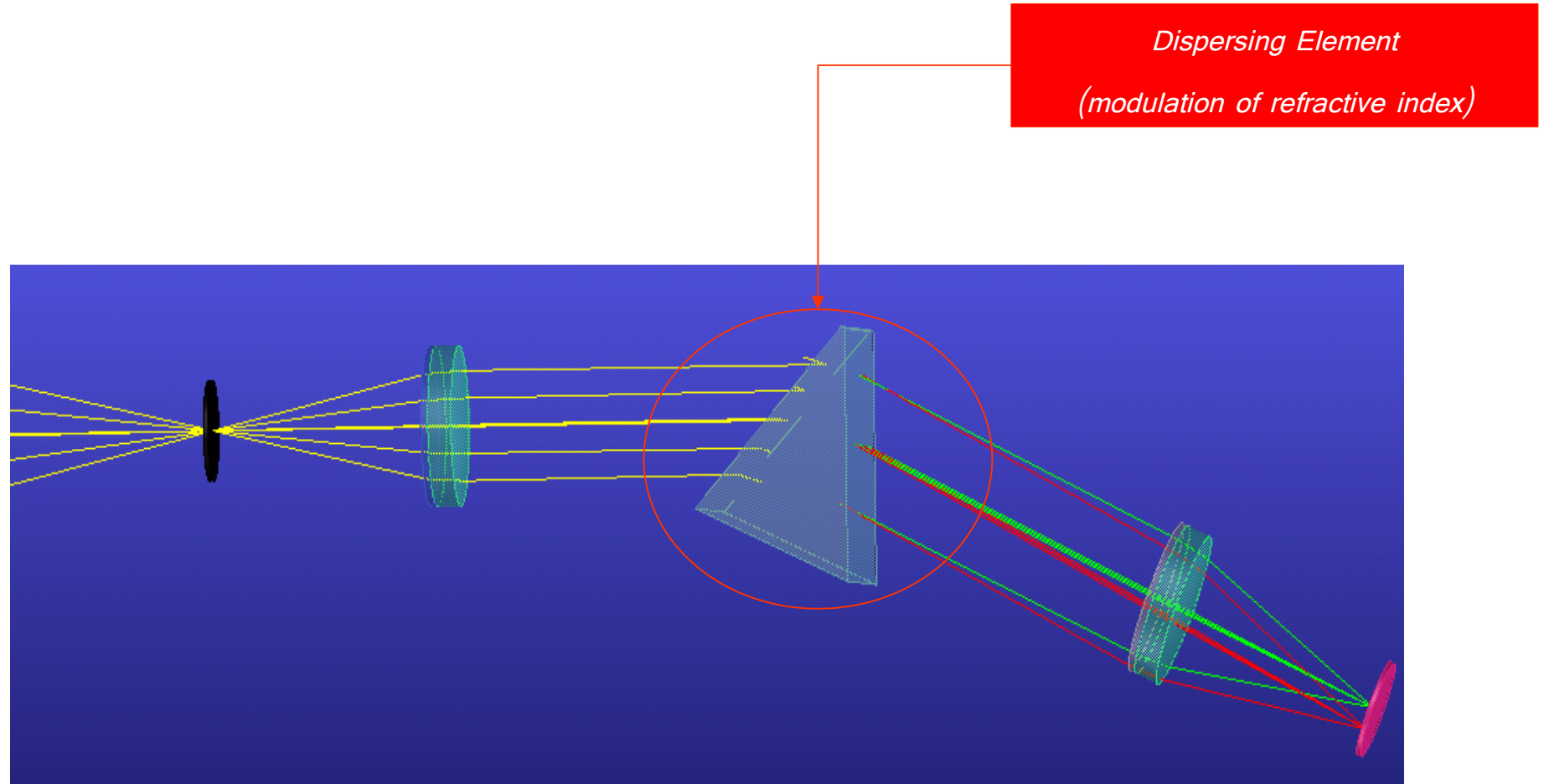

Volume Phase Holographic grating
(VPHG)

Volume Phase Holographic Grating (VPHG)

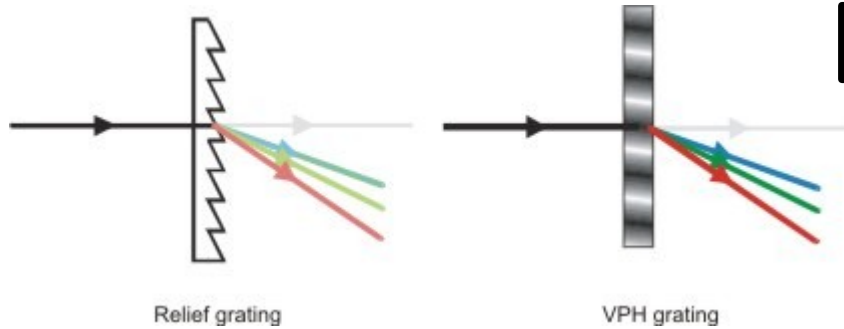

$$m\lambda d = \sin\alpha + \sin\beta$$

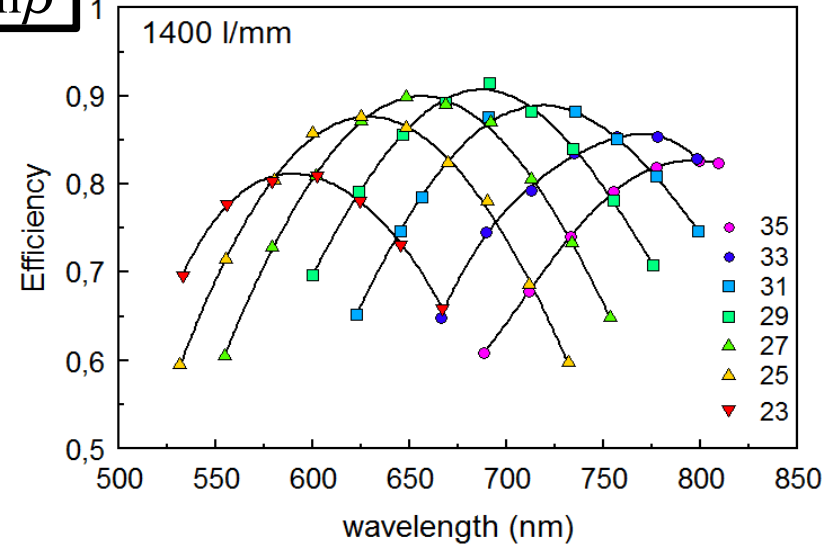

Features

- Peak efficiency ~100% and tunable in wavelength
- Up to 6000 l/mm
- Very large size (up to 40 x 40 cm)
- Easy to customize
- Tunable filters

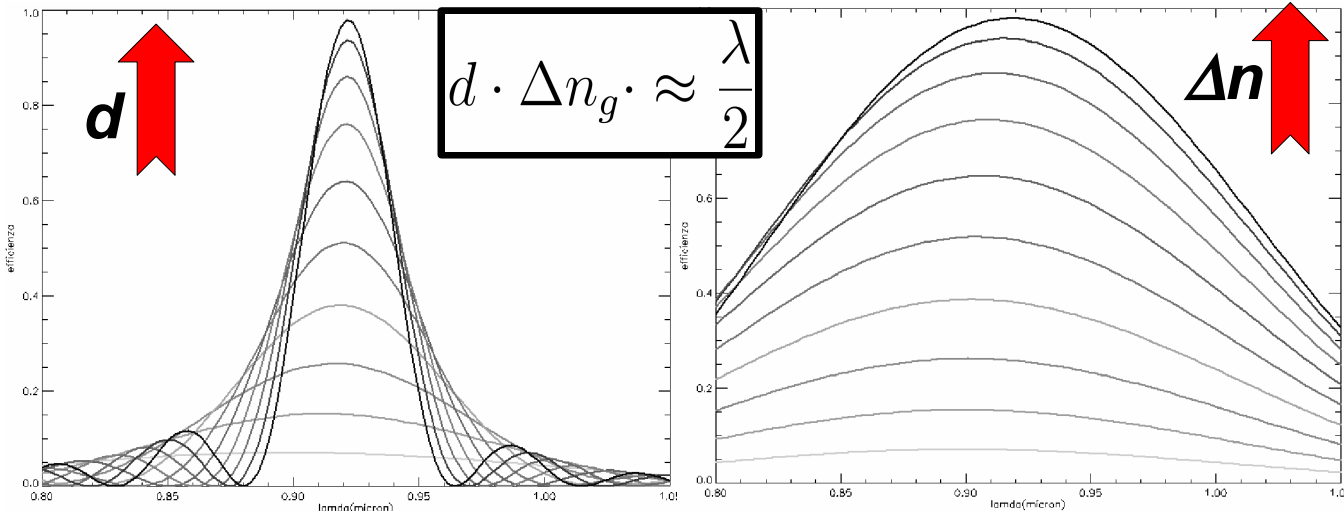

Narrowband tunable filter
(thick film with low modulation)

Traditional VPHG
(thin film with large modulation)

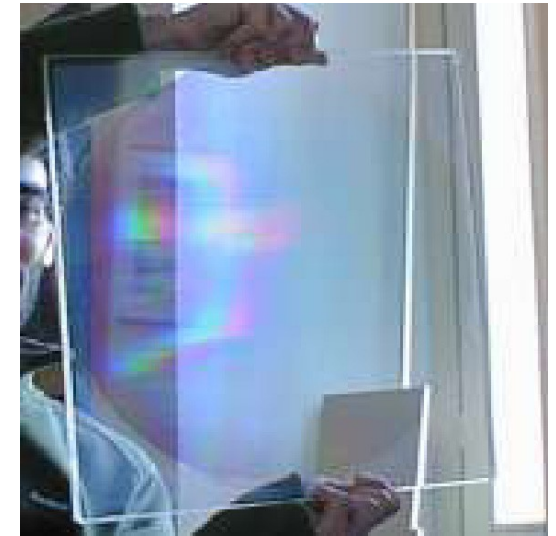

Materials:
dichromated gelatines)

Upgrade of AFOSC and dolores cameras

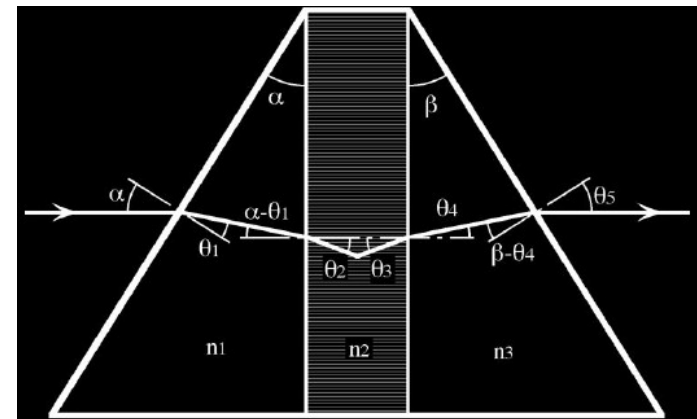
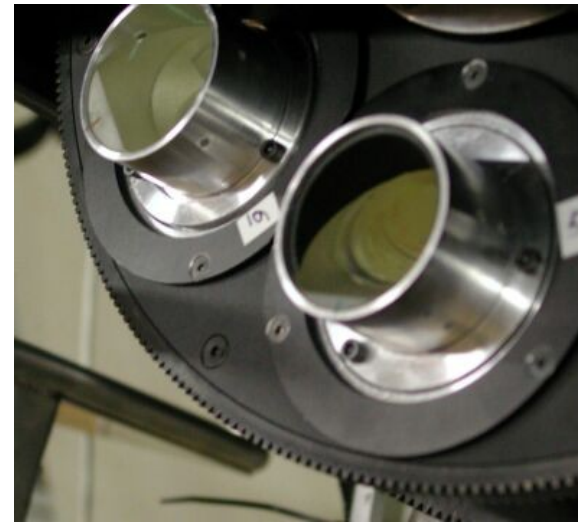
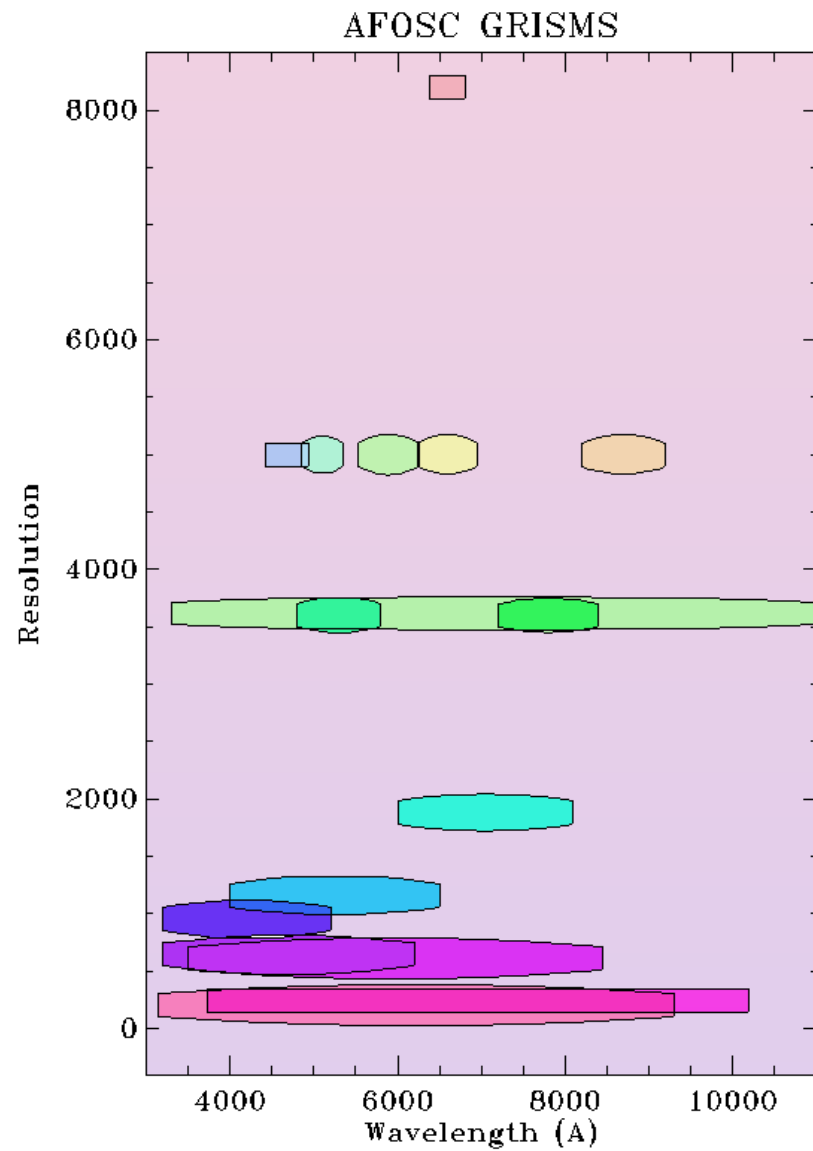

Upgrade of AFOSC and dolores cameras

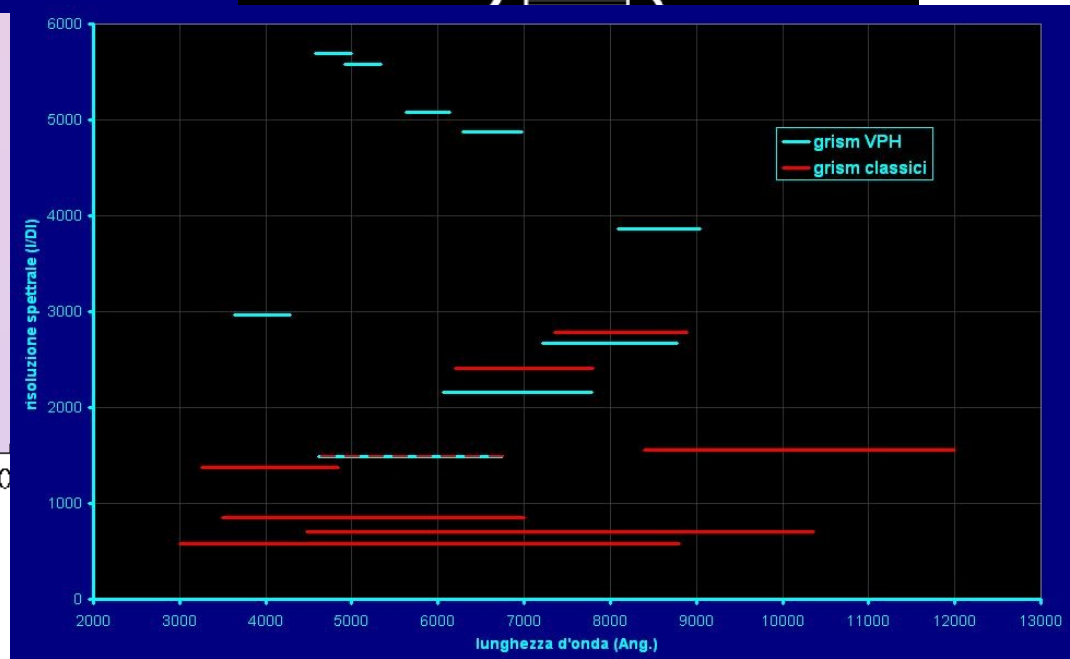
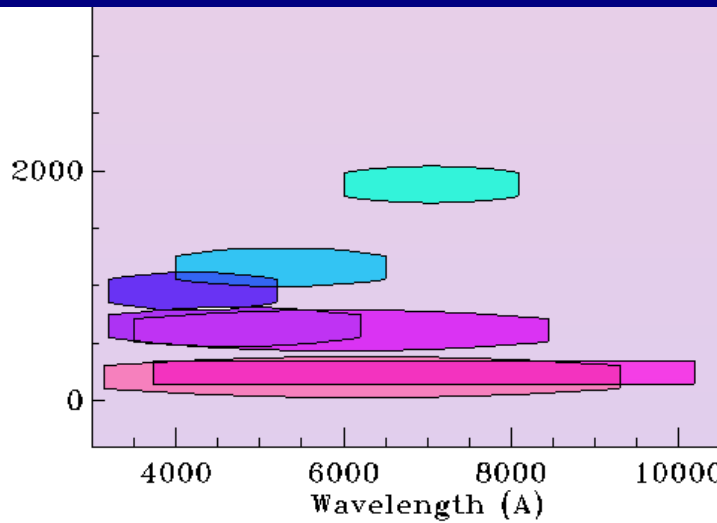
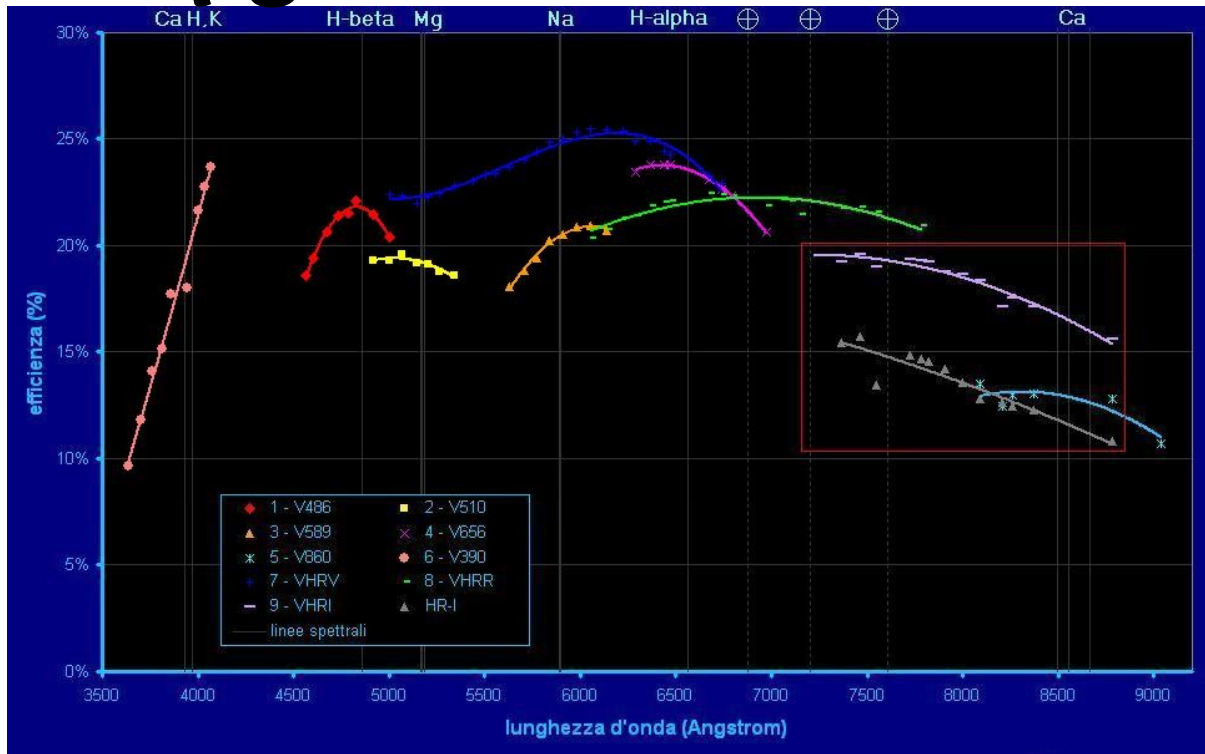

Photochromic VPHG

Why?

- Rewritable
- Easy to produce (no development process, dichromated gelatine)
- Overcome the “thickness limit”

Steps

- Optimization of the modulation of the refractive index (Δn)
- Realization of thin film + large Δn (traditional VPHG) (A)
- Realization of thick film + small Δn (tunable filters) (B)
(Optical and mechanical constrains)

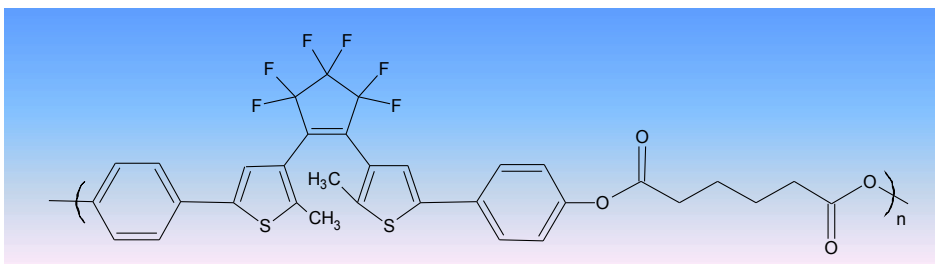

Photochromic polymer
(no polymer matrix)

(A)

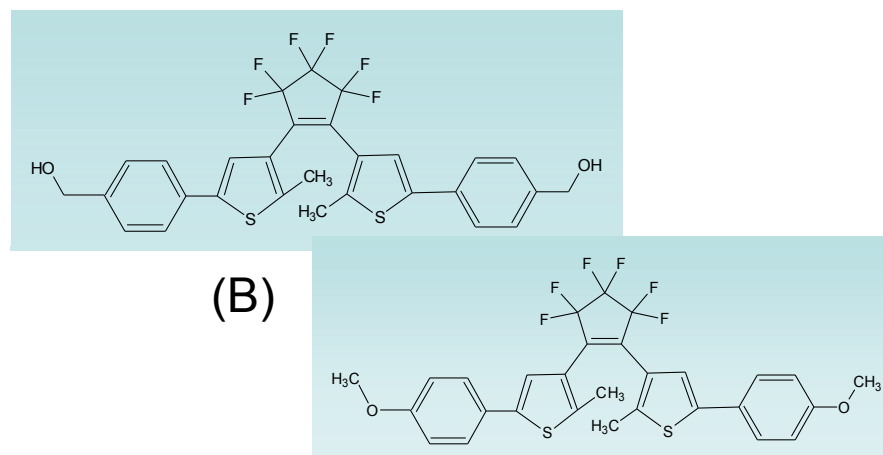

(B)

A polymer matrix is needed

Caratterizzazione: determinazione delle costanti ottiche (poliestere)

Determinazione di indice di rifrazione, in riflessione
film sottili, qualche 10-100 nm (Spin coating)
intervallo spettrale UV-VIS-NIR.

Riflettanza spettrale

riflessione
a incidenza normale
semplice

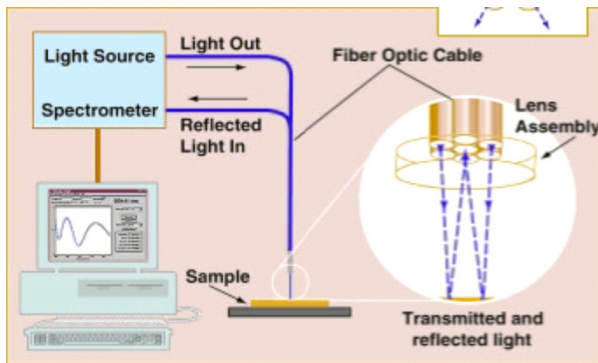

Ellissometria

riflessione
a diversi
angoli di incidenza
e polarizzazione
complessa

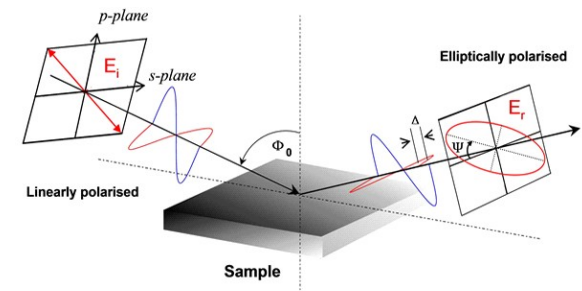

modello di Cauchy per n

indice di rifrazione n
Spessore
Rugosità
Uniformità
del film

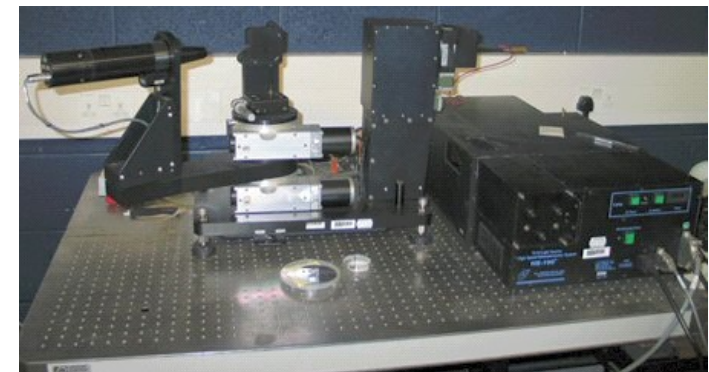

Misure di indice di rifrazione poliestere fotocromico

forma aperta $n=1.5542 \pm 0.000...$
 1500nm forma chiusa $n=1.5953 \pm 0.000...$

$Dn=0.041$
 Chiuso più sottile

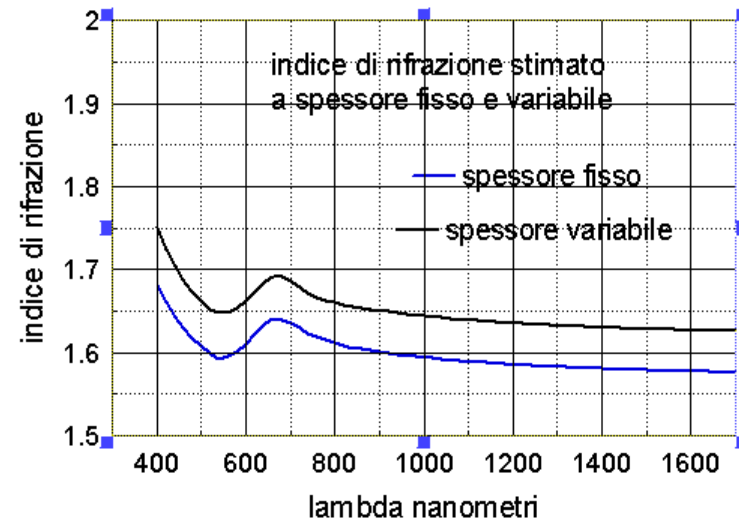
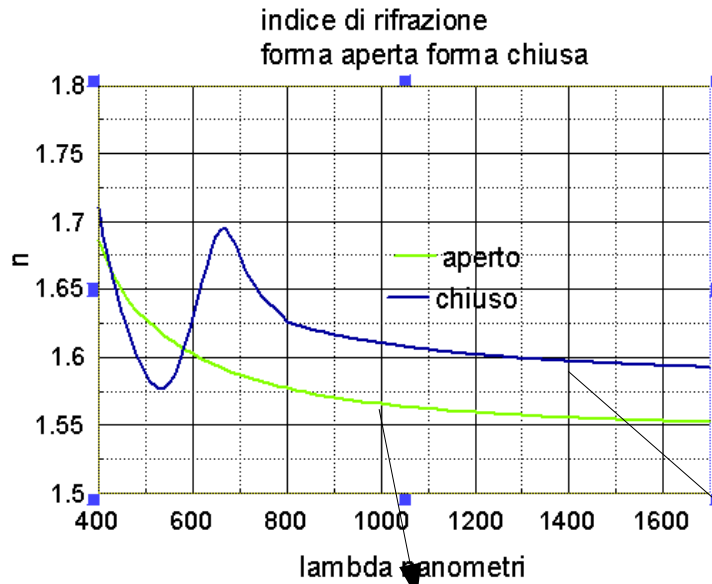

variazione di n , considerando
 lo spessore variabile e **costante**
 raddoppia il contrasto!!

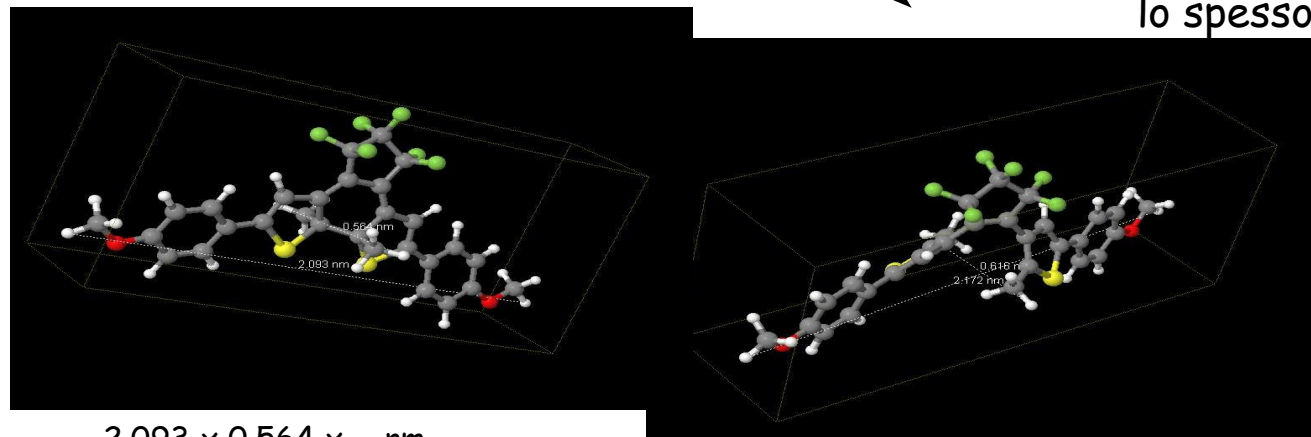

2.093 x 0.564 x ... nm

2.172 x 0.616 x ... nm

Geometria ottimizzata da Conti DFT (B3LYP,6-31G**) Density functional theory.

*Nella conversione
 fra le due forme
 variazione
 spessore = 2%.*

Writing a VPHG

- A **precision Ronchi ruling glass slide** is used as master (600 l/mm, OD = 3)
- A film of P1 is cast on a glass slide => **thickness 5 μm** too small!!
- A green laser (532 nm, 35 mW nominal power) is used to write the pattern (1 cm² area)

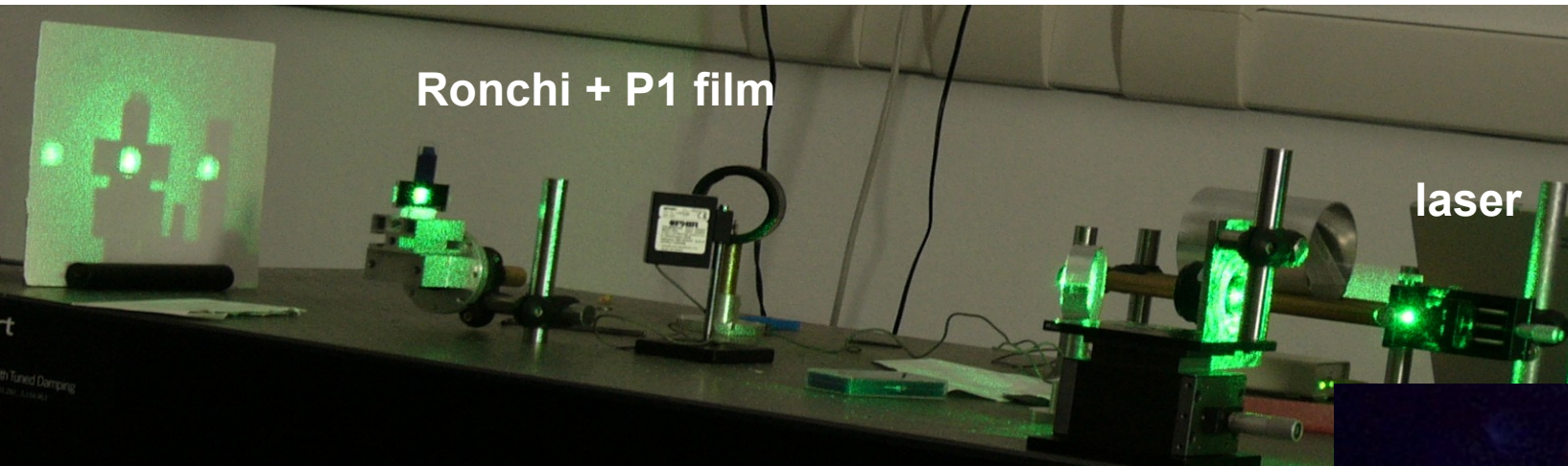

Flashing the photochromic film, after the writing step, with white light, it is decomposed into its components => the pattern is transferred to the film.

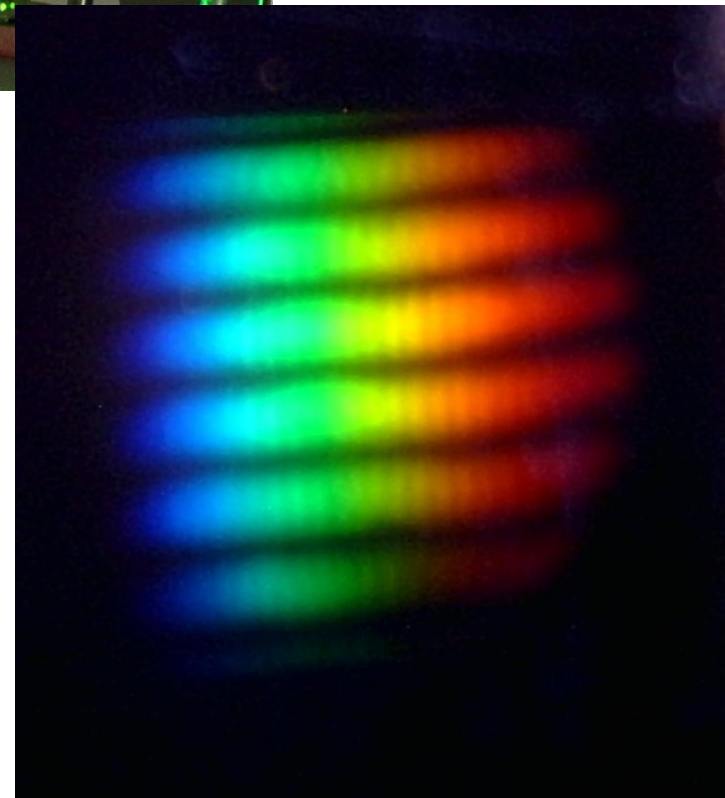
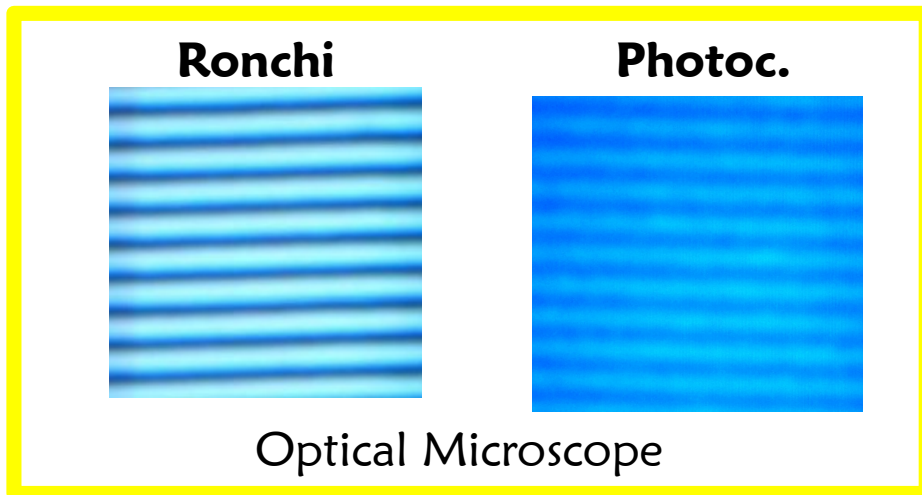

Tunable Filters (narrow band)

Small Δn – Thick films

VPHG efficiency

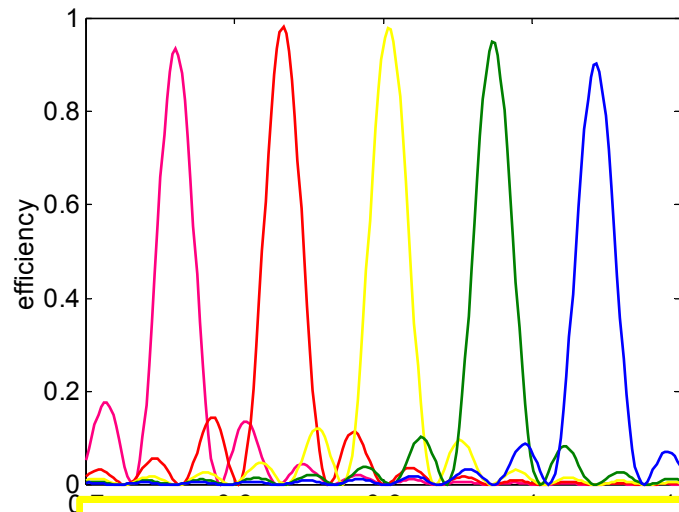

$d=100 \mu\text{m}$ $\Delta n=0.0045$
 $\alpha_0=18^\circ$ 900 l/mm
 $\Delta\alpha=2^\circ$



Filter efficiency (2VPHGs)

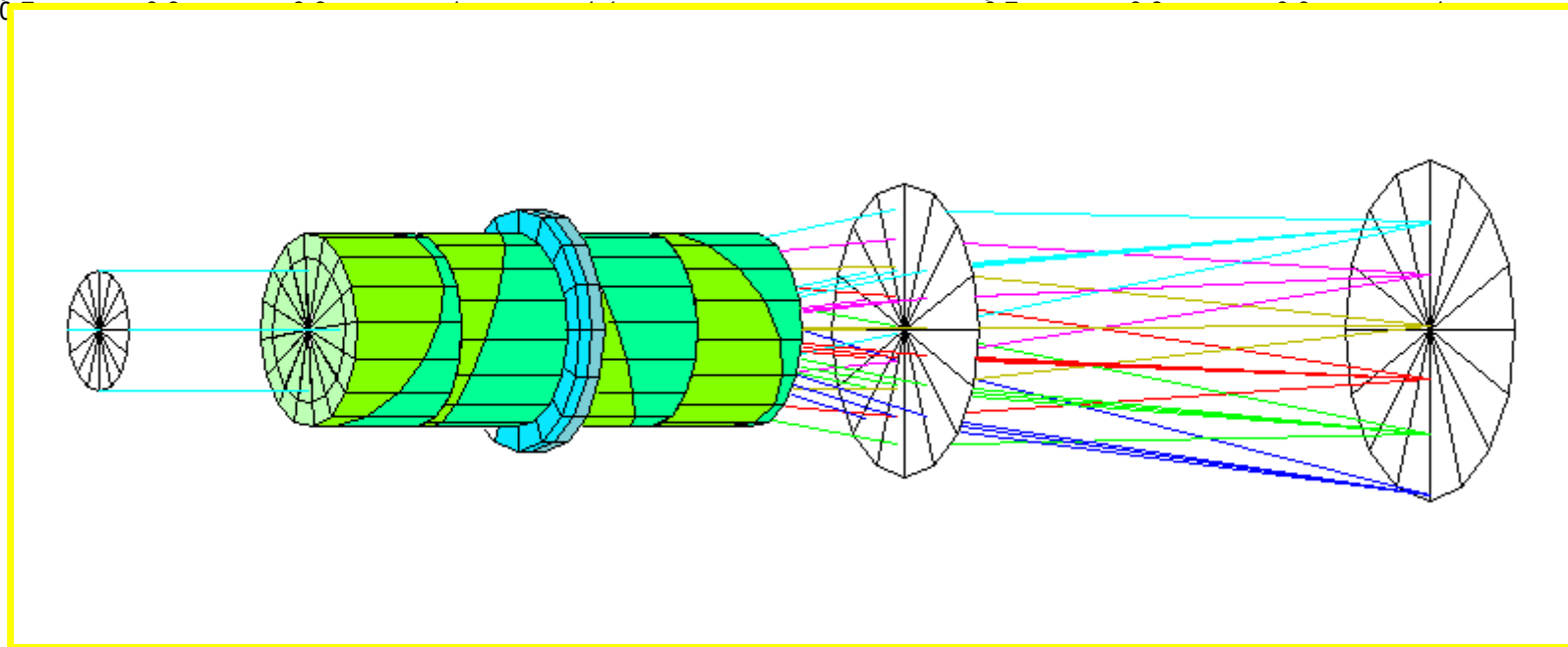
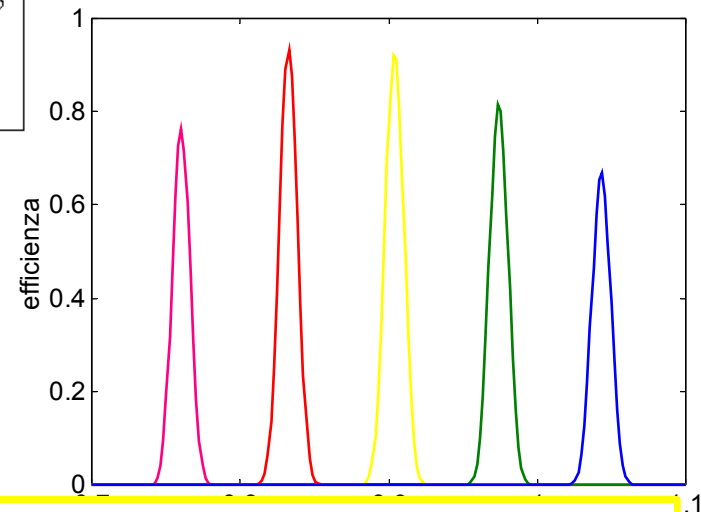

Tunable Filters (narrow band)

Small Δn – Thick films

